

품번 NO.	명칭 DESCRIPTIONS	수량 QTY	재질 MATERIAL	비고 REMARKS
				A3

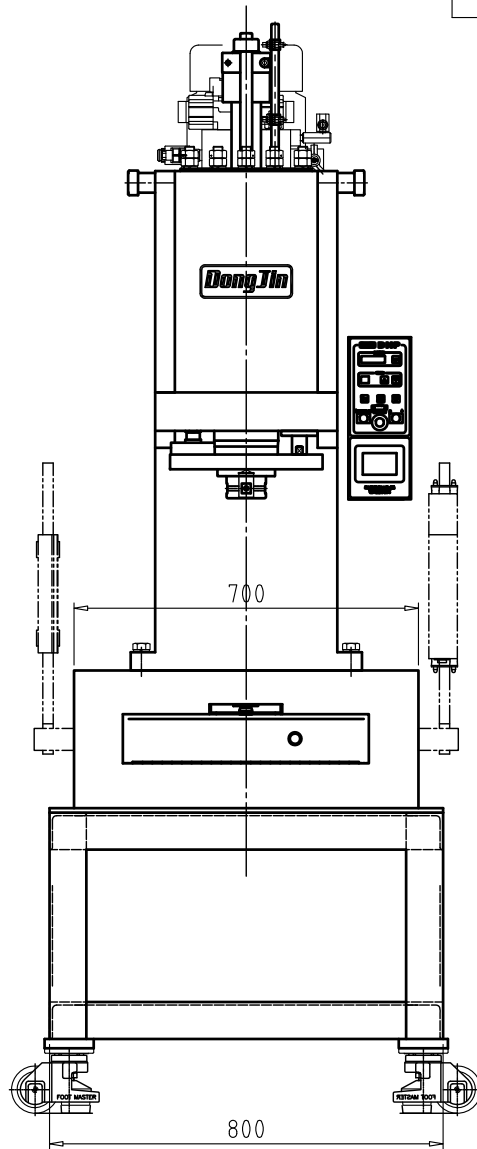

SPECIFICATIONS

CAPACITY	20Ton
STROKE	150mm
OPEN HEIGHT	350mm
APPROACH SPEED	199mm/s.
PRESS SPEED	20mm/s.
RETURN SPEED	118mm/s.
WORKING PRESSURE	160kg/cm ²
HYDRAULIC MOTOR PUMP	3.75kw*4p
MAIN POWER	3φ, 220V/380V
CONTROL POWER	DC24V

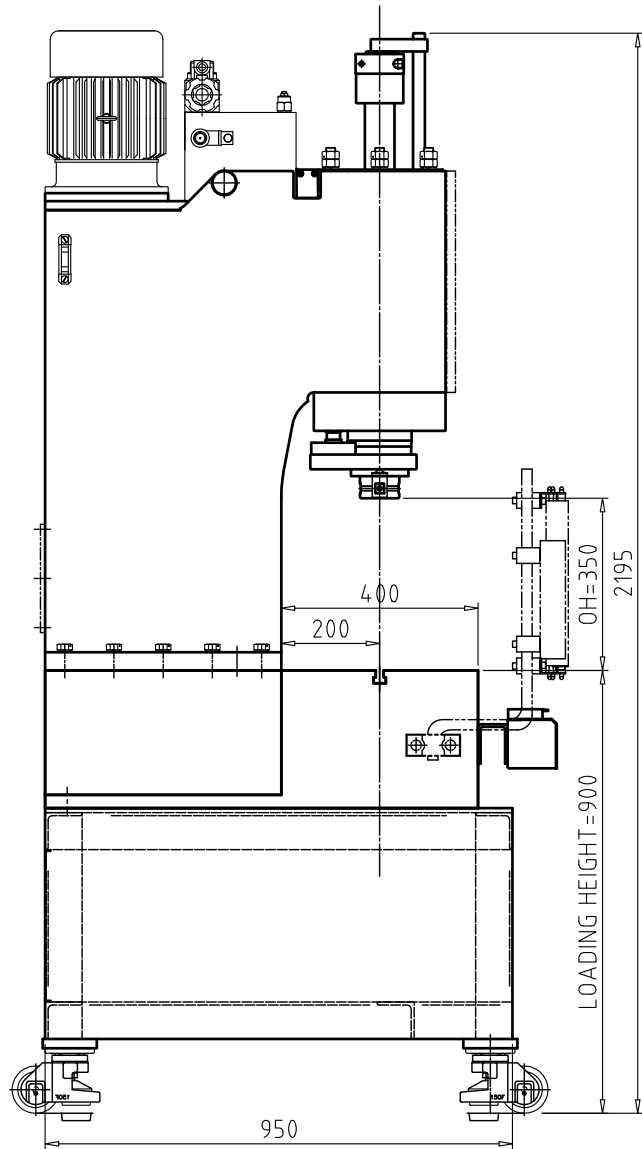
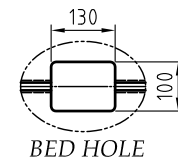
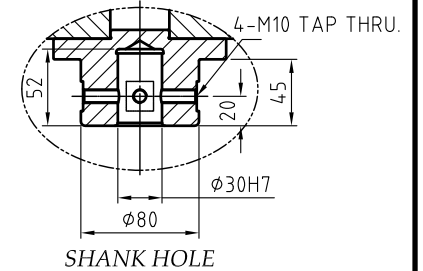
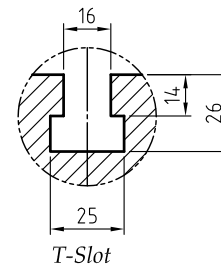

일반 가공치수 허용차	
범 위	공 차
0.5 ~ 6까지	±0.05
6 ~ 120까지	±0.1
120 ~ 315까지	±0.2
315 이상	±0.3
지시없는 모따기 및 라운드	R = C =

				명칭 NAME DHP-20M LAYOUT DRAWING	
				제 도 DR' BY	
				심 계 DES' BY	
기 호 MARK 1 / 11				검 도 CH' BY	
변 정 사 항 REVISION				승 인 PER' BY	
일 자 DATE				도 번 DWG. NO.	
서 명 APPROVED				2012. 7. 31	
척 도 SCALE 1 : 11				도 번 DWG. NO.	
(株) 東進機械 Dong Jin Machinery Co., Ltd.					